

## RGBW UFO



### APPLICATIONS

- Individual buildings
- External wall lighting
- Interior partial lighting
- Green landscape lighting
- Billboard lighting
- Medical lighting
- Bars
- Dance halls

### PRODUCT SPECIFICATIONS

WATTAGES	100W, 150W, 200W, 250W
COLOR TEMPS	RGBW; White options- 40K, (Special order- 65K)
INPUT VOLTAGE	120/277V
CRI	Ra>80
BEAM ANGLE	120°
OPERATING TEMP	-4° to 104°F
FIXTURE COLOR	Black
DIMENSIONS	100W- 11.02" x 9.57" 150W- 13.39" x 10.43" 200W+250W- 15.75" x 10.43"
CONTROLS	DMX12 Driver Remote (Sold Separately) Tuya App Compatible
REMOTE	Sold Separately
RATED	IP65
LISTED	ETL
WARRANTY	5 year



### PRODUCT BUILDER

ex: ZL-UFO-100W-RGBW-40K-TR

TYPE	WATTAGE	COLOR TEMP	COLOR TEMP
ZL-UFO		RGBW	
	100=100W 150=150W 200=200W 250=250W		40K=4000K 65K=6500K (special order)
			TR



## RGBW UFO

### WIRING DIAGRAM

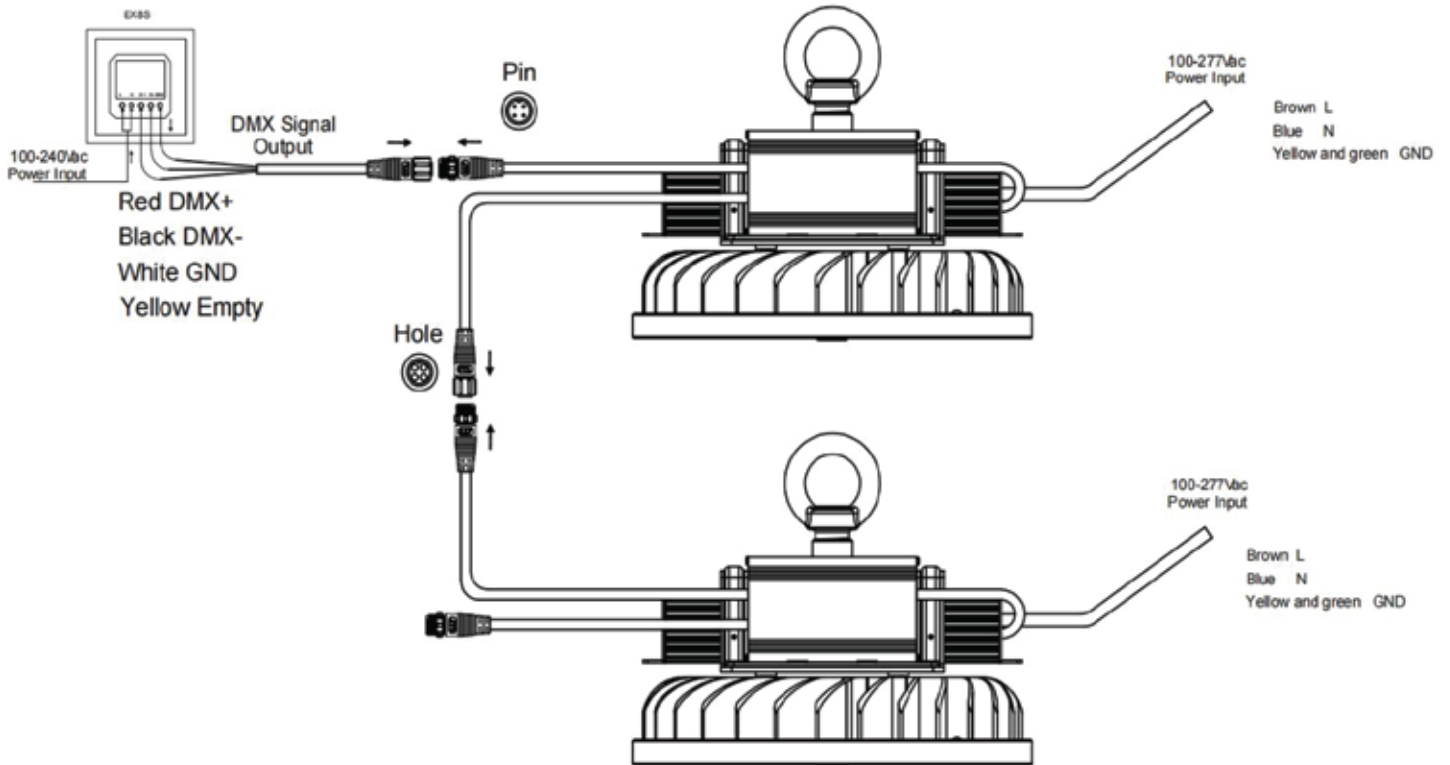

### RGB/RGBW TOUCH WHEEL RF REMOTE CONTROLLER

- Apply to RGB or RGBW LED controller.
- Ultra sensitive color adjustment touch wheel.
- Independent dimming function of each R, G, B, W channel to achieve millions of colors.
- Each remote can match one or more receiver.
- AAAx2 battery powered.
- Operate with LED indicator light.

**Remote Part #:**  
ZL-REMOTE-RT4  
ZL-REMOTE-RT9



RT4  
1 Zone RGB/RGBW



RT9  
4 Zone RGB/RGBW

CE RoHS  RED

#### Technical Parameters

Input and Output		Safety and EMC		Environment	
Output signal	RF(2.4GHz)	EMC standard (EMC)	ETSI EN 301 489-1 V2.2.3 ETSI EN 301 489-17 V3.2.4	Operation temperature	Ta: -30 °C ~ +55 °C
Working voltage	3VDC(AAAx2)	Safety standard	EN 61348-1:2015+A1:2021 EN 61348-2-13:2014+A1:2017	Package	
Working current	<5mA	Radio Equipment(RED)	ETSI EN 300 328 V2.2.2	Size	L140 x W60 x H26mm
Standby current	<10µA	Certification	CE,EMC,RED	Gross weight	0.088kg
Standby time	1 year			Warranty	
Remote distance	30m(Barrier-free space)			Warranty	5 years

## RGBW UFO

### RGB/RGBW TOUCH WHEEL RF REMOTE CONTROLLER

#### Mechanical Structures and Installations

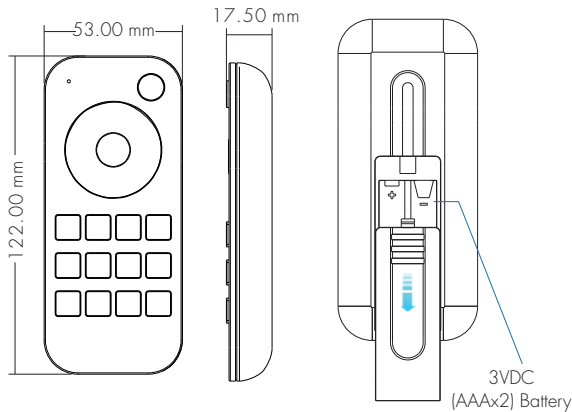

#### Back holder

Two options are offered for selection, please fix the back holder on the wall with two screws, or adhere the back holder to the wall with paster.

##### 1. Back holder without magnet

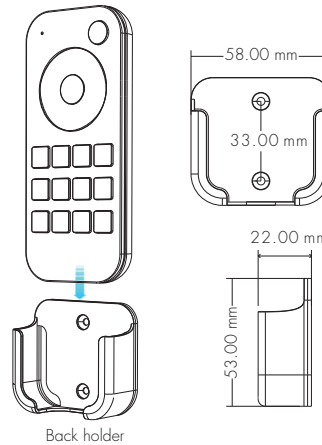

##### 2. Back holder with magnet (The remote with built-in magnet)

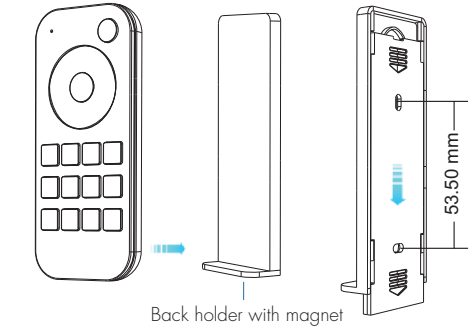

#### Operation

- When turn on light, the indicator display blue. when turn off light, the indicator display red.
- When touch the color wheel, the indicator will display the same color.
- When press or touch operation is invalid (If the light is off), the indicator display red.
- To extend battery life, no touch or press key operation after a few seconds, the touch wheel will enter sleep state, you need press any key to make touch wheel quit sleep state.

#### Match Remote Control (two match ways)

End user can choose the suitable match/delete ways. Two options are offered for selection:

##### Use the controller's Match key

Match:

Short press match key, immediately press on/off key (single zone remote) or zone key (multiple zone remote) of the remote.

The LED indicator fast flash a few times means match is successful.

Delete:

Press and hold match key for 5s to delete all match,

The LED indicator fast flash a few times means all matched remotes were deleted.

##### Use Power Restart

Match:

Switch off the power, then switch on power, repeat again.

Immediately short press on/off key (single zone remote) or zone key (multiple zone remote) 3 times on the remote.

The light blinks 3 times means match is successful.

Delete:

Switch off the power, then switch on power, repeat again.

Immediately short press on/off key (single zone remote) or zone key (multiple zone remote) 5 times on the remote.

The light blinks 5 times means all matched remotes were deleted.



1pcs wireless remote controller can control max 60 lights.  
The distance is 30m.



## RGBW UFO

### WIFI & RF 3 IN 1 DMX512 MASTER

- WiFi & RF RGB/RGBW/RGB+CCT 3-in-1 DMX512 master, Max 512 channel output.
- Comply with the DMX512 standard protocols, compatible with DMX decoder from other supplier.
- Tuya Smart APP cloud control.
- Voice control, support for Amazon Alexa, Google Assistant, Tmall Genie and Xiaodu voice assistant.
- Painted segment color mixing: full color filling, color pencil segment painting, eraser segment light off.
- Rich dynamic effects: 44 default and 10+ custom dynamic scenarios, 16 variations.
- 3 APP music rhythms.
- Connect with external two push switch, supports on/off, brightness adjustment, dynamic mode change type and speed settings.
- Match with RF 2.4G remote control optional, such as R9.

**Part #:**  
ZL-DMX512



**CE RoHS**

#### Technical Parameters

Input and Output		Safety and EMC		Environment	
Input voltage	12-36VDC	EMC standard	EN IEC 55015/EN IEC 61547 ETSI EN 301 489-1/-3/-17	Operation temperature	Ta: -20°C ~ +55°C
Input signal	WiFi, RF 2.4G, Push switch	Safety standard	EN 61347-1/-2	Case temperature (Max.)	Tc: +65°C
Output signal	DMX512 (multipixel)	Radio Equipment	ETSI EN 300 440 ETSI EN 300 328	IP rating	IP20
Channel number (Pixel Dots)	Max 512 Channel RGB: 170 pixels RGBW: 128 pixels RGB+CCT: 102 pixels	Certification	CE RoHS	<b>Package</b>	
		<b>Warranty</b>		Size	L120 x W43 x H27mm
		Warranty	5 years	Gross weight	0.055kg
		Protection	Reverse polarity		

#### Mechanical Structures and Installations

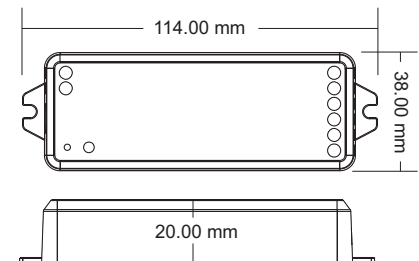
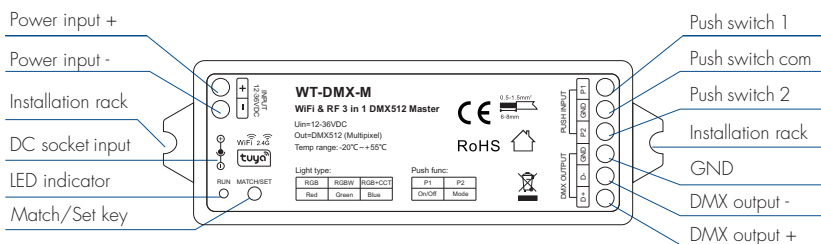

# RGBW UFO

## WiFi & RF 3 IN 1 DMX512 MASTER

### System Wiring

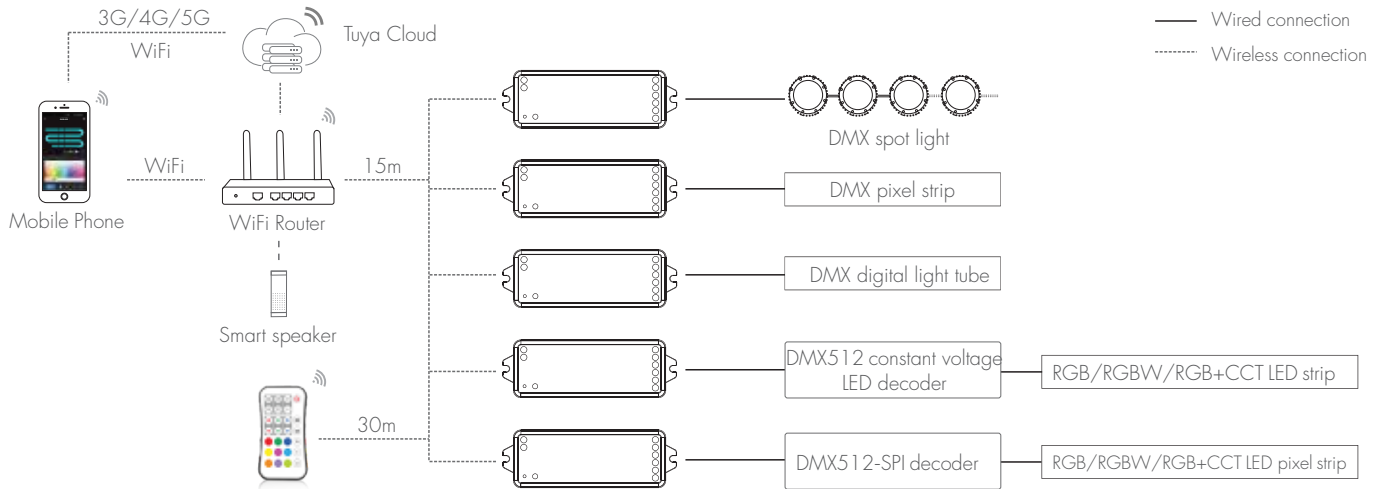

Note:

1. The above distance is measured in spacious (no obstacle) environment, Please refer to the actual test distance before installation.
2. Please check if the WiFi router net in 2.4G band, the 5G band is not available, and do not hide your router network.
3. Please keep the distance between WT-DMX-M devices and router close, and check the WiFi signals.
4. WiFi signal strength detection: open the main interface of social security, click  enter the device interface, click "check device network" for testing.

### Wiring Diagram

1. WT-DMX-M connect with DMX512 spot light

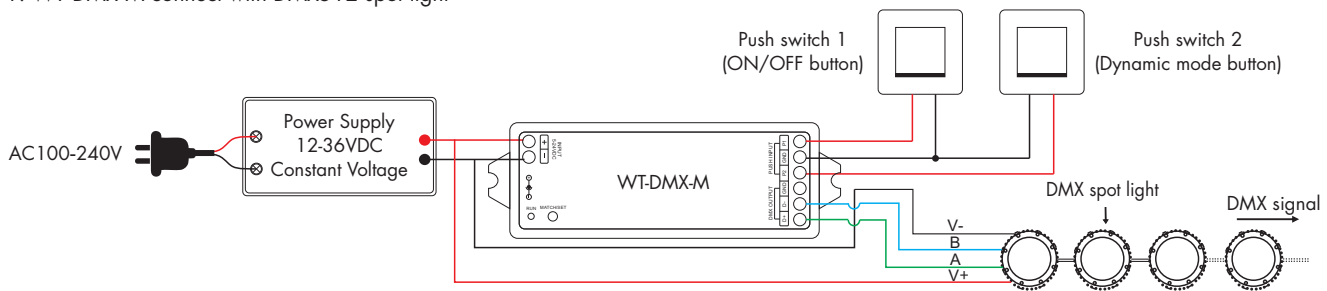

2. WT-DMX-M connect with DMX512 pixel strip

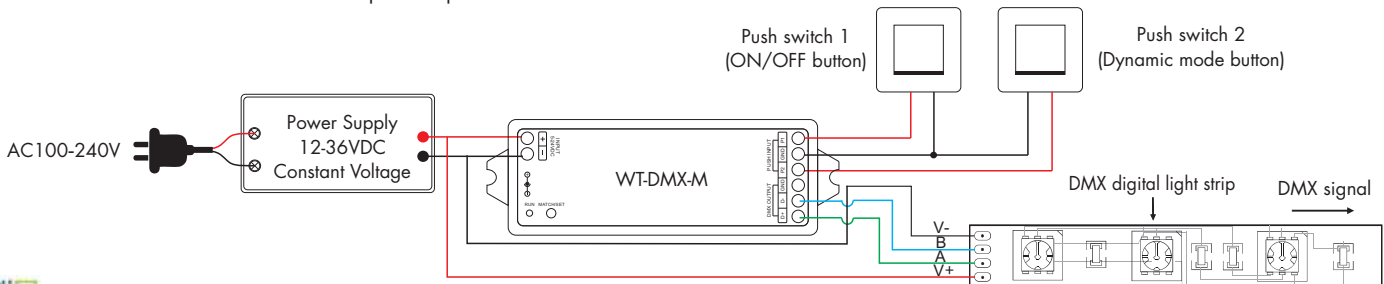

# RGBW UFO

## WIFI & RF 3 IN 1 DMX512 MASTER

3. WT-DMX-M connect with DMX512 Digital light tube

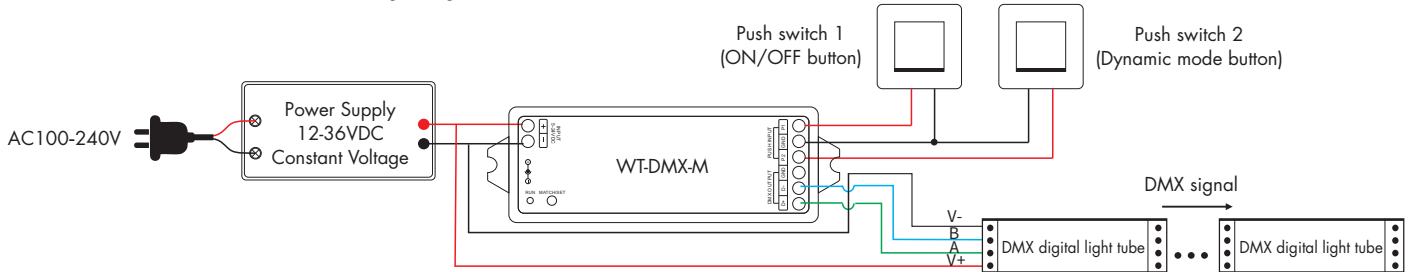

4. WT-DMX-M connect with multiple DMX512 constant voltage decoder

(Connecting multiple four-channel constant voltage DMX512 decoders to control multiple RGBW LED strips as an example)

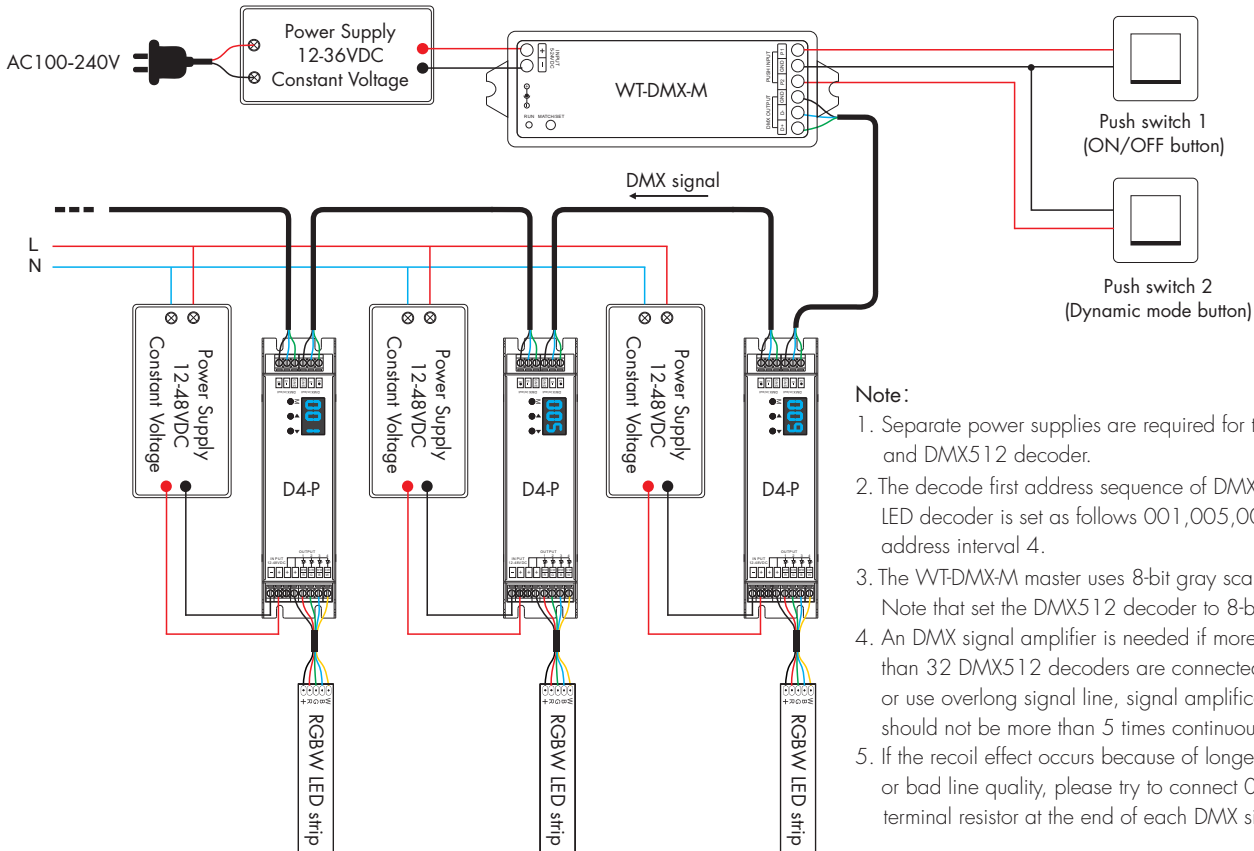

**Note:**

1. Separate power supplies are required for the DMX512 master and DMX512 decoder.
2. The decode first address sequence of DMX512 constant voltage LED decoder is set as follows 001,005,009, ..., 509, address interval 4.
3. The WT-DMX-M master uses 8-bit gray scale output.  
Note that set the DMX512 decoder to 8-bit decode mode.
4. An DMX signal amplifier is needed if more than 32 DMX512 decoders are connected, or use overlong signal line, signal amplification should not be more than 5 times continuously.
5. If the recoil effect occurs because of longer signal line or bad line quality, please try to connect 0.25W 90-120Ω terminal resistor at the end of each DMX signal line.



## RGBW UFO

### WIFI & RF 3 IN 1 DMX512 MASTER

5. WT-DMX-M connect with one or multiple DMX512-SPI decoder  
(Connecting multiple DMX512 to SPI decoders to control multiple pixel RGB/RGBW LED strips as an example)

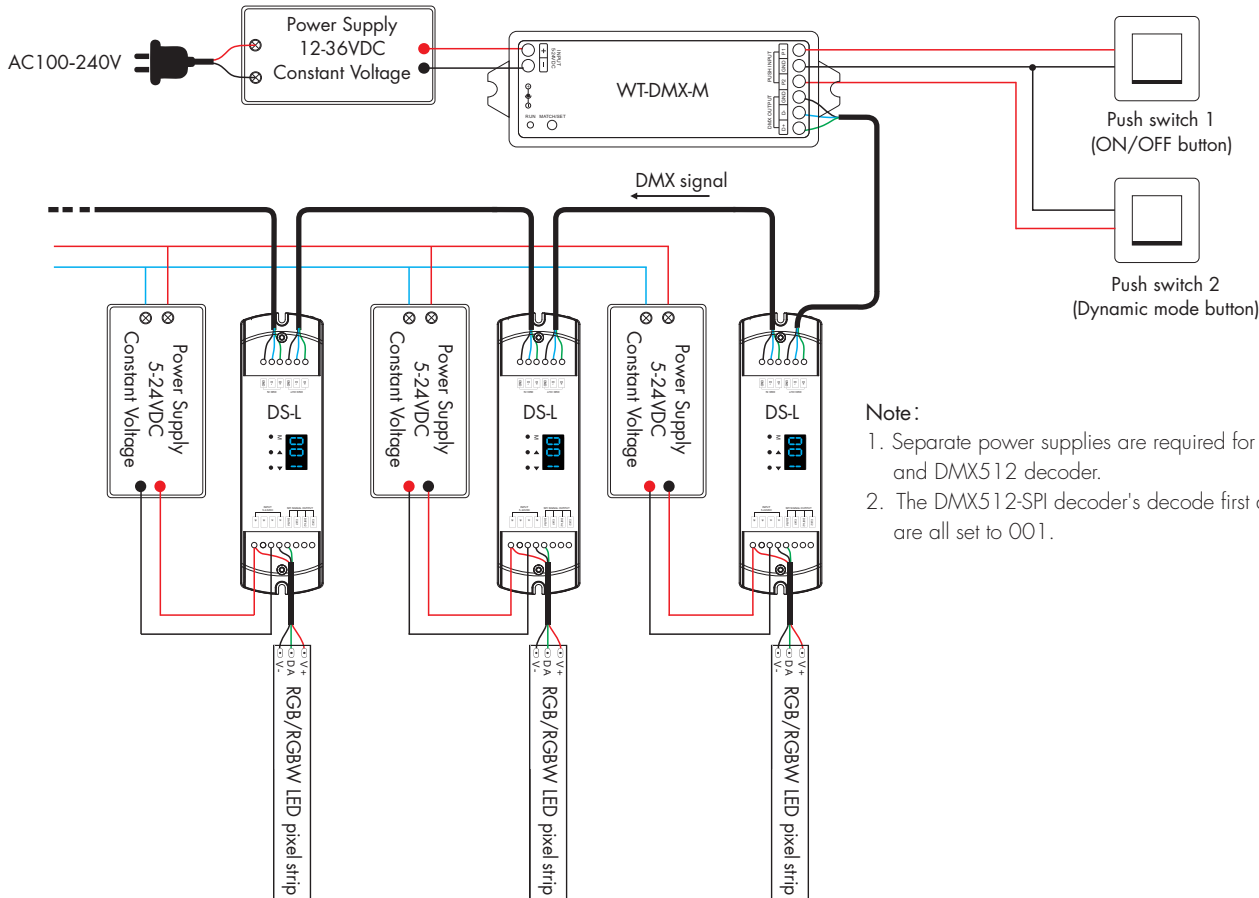

**Note:**

1. Separate power supplies are required for the DMX512 master and DMX512 decoder.
2. The DMX512-SPI decoder's decode first address are all set to 001.

### Push Switch Function

Use the push switch 1 to turn the light on/off or adjust the brightness.

**Push switch 1 (ON/OFF Button)**

**Short press:** Turn on/off the light.

**Long press (1-10s):** Brightness increases or decreases continuously.

Each time you release and then long press again, the brightness changes in the opposite direction.

Increasing or decreasing the brightness by 1 level every 2s, a total of 5 levels of brightness(20%, 40%, 60%, 80%, 100%).

**Push switch 2 (Dynamic Mode Button)**

Use the push switch 2 to switch the dynamic mode change type, direction and speed, and the dynamic mode color is fixed to seven colors (red, yellow, green, cyan, blue, purple and white).

**Short press:** Switch the change type of dynamic mode in sequence, 9 types in total (flow, chase, block, float, trail, trail + black, jump, smooth, chaotic flash).

**Double-click:** Switch the motion direction (forward or reverse) of the dynamic mode.

Jump, smooth, chaotic flash dynamic mode do not support the motion direction setting.

**Long press(1-10s):** Speed increases or decreases continuously.

Each time you release and then long press again, the speed changes in the opposite direction.

Increasing or decreasing the speed by 1 level every 2s, a total of 5 levels of speed.



## RGBW UFO

### WIFI & RF 3 IN 1 DMX512 MASTER

#### Light Type Setting

Long press the Match/set key for 2s, sequential switching of three light types (RGB, RGBW, RGB+CCT), and the RUN indicator changes to the corresponding color (red: RGB, green: RGBW, blue: RGB+CCT). Long press the Match/set key for 1.5s to restore factory defaults. factory default RGB light type, R/G/B color sequence, output 510 channels. If Tuya Smart APP network connection succeed, you can also set light type through the APP.

The channel address correspondence of each pixel point for different light types is as follows:

RGB				RGBW					RGB+CCT					
Pixel	R	G	B	Pixel	R	G	B	W	Pixel	R	G	B	WW	CW
1	1	2	3	1	1	2	3	4	1	1	2	3	4	5
2	4	5	6	2	5	6	7	8	2	6	7	8	9	10
3	7	8	9	3	9	10	11	12	3	11	12	13	14	15
...	...	...	...	...	...	...	...	...	...	...	...	...	...	...
170	508	509	510	128	509	510	511	512	102	506	507	508	509	510

**Note:** When RGBW and RGB+CCT light type, no matter APP interface, push switch or RF remote control operation, when changing the dynamic mode effect, it only changes the R/G/B channel output, i.e., W channel and WW/CW channel are not involved in the dynamic effect output.

#### Tuya Smart APP Network Connection and Operation Interface

Push twice Match key fastly, or press and hold Match key for 5s, clear previous network connection, enter WiFi config mode, LED indicator flash fastly. If Tuya Smart APP network connection succeed, the RUN LED indicator will stop flash, and in Tuya Smart APP, you can find WTDMX:Master device. You can set the number of channels, light type, and R/G/B color sequence through the APP setting interface.

When controlling the light with Tuya Smart/Smart Life APP, if the network connection is poor, you can control the light with Bluetooth connection within the Bluetooth control range.

**Note:** The light can not be directly controlled by Bluetooth without WiFi configuration.

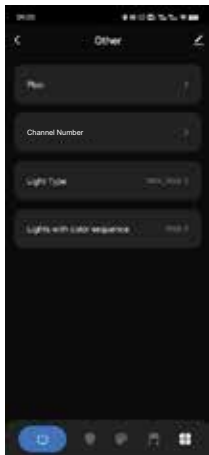

**Other interface**  
For the first time use, set channel number, light type and color sequence.



**Channel number interface**  
According to requirements select number of channels, channel number range:24-512.



**Light type interface**  
Select RGB, RGBW, RGB+CCT light type.

# RGBW UFO

## WIFI & RF 3 IN 1 DMX512 MASTER



**Lights with color sequence interface**

Select the corresponding R/G/B/W sequence according to the color sequence of the light.  
(RGB, RBG, GRB, GBR, BRG, BGR, RGBW, RBGW, GRBW, GBRW, BRGW, BGRW, WRGB, VRBG, WGRB, VGBR, WBRG, WBGR)

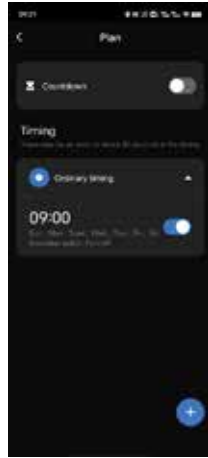

**Plan interface**

Countdown:  
Customize the countdown time (Max.24 hours) to perform the on/off action.  
Timer: Customize multiple times to perform the on/off light action.



**Colour:**

Touch the color rectangle to adjust color and saturation.  
Touch the brightness slide to adjust brightness.



**White:**

Touch the color rectangle to adjust color temperature.  
Touch the brightness slide to adjust brightness.  
RGB or RGBW light types  
Use R/G/B mixing to simulate color temperature.



**Color Card:**

Touch the color card array to select many different colors.  
Touch the brightness slide to adjust brightness.



**Combination:**

Select a proportional distribution of multi-color circle, evenly distribute these colors on the LED strip.



## RGBW UFO

### WIFI & RF 3 IN 1 DMX512 MASTER



Color Fill: Change the color of the full segment of the LED strip.



Color pen: change the color of a single segment of the LED strip.



Eraser: Erase the color of a single segment of the LED strip, i.e., turn off the light.



Color transition: When there are multiple colors in the LED strip, you can set to turn on or off the color segment gradient transition.

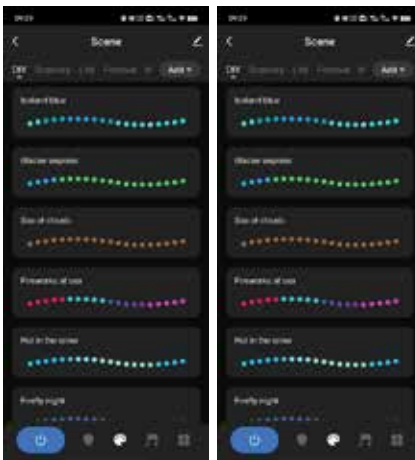

#### Scene interface

44 predefined scenarios and 10+ custom dynamic scenarios selectable. The custom scenarios can select 16 types variations (fade, jump, breath, flash, flow, rainbow, shooting star, pile-up, floating down, chasing light, floating, flashing, bouncing, shuttle, chaotic flashing, open and close), the 1-8 colors, full or segment control, forward or reverse motion direction, adjustable brightness and speed.

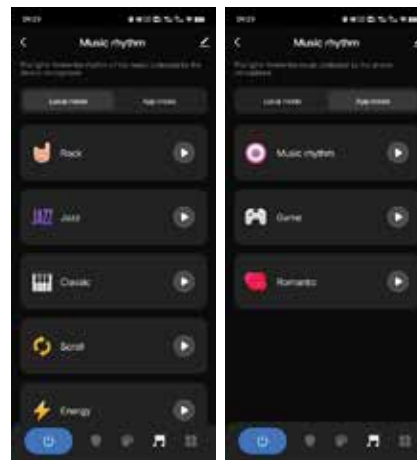

#### Music rhythm interface

6 local music modes (rock, jazz, classical, rolling, energy, spectrum) selectable. 3 APP modes (music rhythm, game, romance) selectable. Adjustable sensitivity of the received sound. The light follows the rhythm according to the music collected by the phone microphone.

Note: the DMX512 master only supports APP mode.



## RGBW UFO

### WIFI & RF 3 IN 1 DMX512 MASTER

#### RF Remote Control

The DMX512 master can be matched with optional R9 remote control, then through the remote control to switch static or dynamic mode, set the R/G/B color sequence and the number of output channels.

#### Remote control match and deletion method:

Match: Short press match key, immediately press on/off key of the remote.

Delete: Press and hold match key for 10s to delete all match, LED indicator flash fastly means all matched remotes were deleted.

#### R9 remote control set R/G/B color sequence and number of output channels:

1. The DMX signal default to the RGB color order. If the RGB color is not correct,

you can change the R/G/B color order by pressing 3 buttons (\* + 1 digit + \*): \*1\*:RGB, \*2\*:RBG, \*3\*:GRB, \*4\*:GBR, \*5\*:BRG, \*6\*:BGR.

2. DMX signal output default 512 channels, you can set the number of channels (024-512) by pressing five buttons (\* + 3 digits + \*) consecutively, e.g.: \*060\* to set 60 channel outputs.

#### R9 remote control calls up dynamic modes list:

No.	Name	No.	Name	No.	Name	No.	Name
P01	Red horse race white ground	P11	7 color multi-scan close + open	P21	Green float	P31	7 color jump sectionally
P02	Green horse race white ground	P12	Blue White chase	P22	Blue float	P32	7 color strobe sectionally
P03	Blue horse race white ground	P13	Green Cyan chase	P23	Purple float	P33	White horse race (RGB jump)
P04	Yellow horse race blue ground	P14	RGB chase	P24	RGBW float	P34	White smooth horse race (RGB smooth)
P05	Cyan horse race blue ground	P15	7 color chase	P25	Red Yellow float	P35	White starlight (RGB random jump)
P06	Purple horse race blue ground	P16	Blue meteor	P26	Green Cyan float	P36	White smooth starlight (RGB random smooth)
P07	7 color multi horse race	P17	Purple meteor	P27	Blue Purple float	P37	White flow,forward
P08	7 color horse race close + open	P18	White meteor	P28	Blue White float	P38	White flow,forward on +backward off
P09	7 color multi horse race close + open	P19	7 color meteor	P29	6 color float	P39	White flow,forward on +backward on
P10	7 color scan close + open	P20	Red float	P30	6 color smooth sectionally	P40	White float,forward

#### Note:

P33-P40 dynamic modes are applicable to DMX type white light strip.

P33-P36 dynamic modes, if the color DMX strip is connected, the corresponding color effect will appear.

