

RGB/DMX LINEAR LED WALL WASHERS

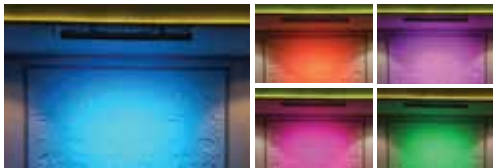

IP65



APPLICATIONS

Suitable for indoor and outdoor lighting, hotel lighting, plaza lighting, building lighting, museum lighting, landscape lighting and more.

PART NUMBERS

30K	40K	RGB
ZPW-30K-300-9W	ZPW-40K-300-9W	ZPW-RGB-300-9W
ZPW-30K-600-18W	ZPW-40K-600-18W	ZPW-RGB-600-18W
ZPW-30K-1000-30W	ZPW-40K-1000-30W	ZPW-RGB-1000-30W
ZPW-30K-1200-36W	ZPW-40K-1200-36W	ZPW-RGB-1200-36W

NOTE: The beam angle for all products is 45 degrees. Power and control cords are 2ft. in length standard. This allows for a 4ft. spacing between multiple units. Custom jumper lengths are also available.

PRODUCT SPECIFICATIONS

WATTAGES	9W, 18W, 30W, 36W
COLOR TEMPS	30K, 40K, RGB; {Special order: 35K}
EFFICACY	80-100 lm/W
INPUT VOLTAGE	96-256VAC
DIMENSIONS	300MM - 9W (11.81 inches) 600MM - 18W (23.62 inches) 1000MM - 30W (39.37 inches) 1200MM - 36W (47.24 inches) {Special Order - 500mm - 12W (19.65 inches) Contact Factory} (Lumens the same as 600mm)
BEAM LENGTH	9W- 16-33 ft; 18W- 26 ft 30W+36W- 50-65 ft
LED LIFESPAN	50,000 hours
DAISY CHAIN	Up to 82 units for up to 328 feet in length including power cords.
BEAM ANGLE	45° Standard 15°, 30°, 60° Special Order
MOUNTING	Surface Mount
RATED	IP65
WARRANTY	3 year

LUMENS

	30K	40K	RGB
9W	720	900	411
18W	1,440	1,800	849
30W	2,400	3,000	1,359
36W	2,880	3,600	1,700

ACCESSORIES

PRODUCT #	DESCRIPTION
ZPW-PJ-2FT	2ft. Power jumper cord
ZPW-PJ-10FT	10ft. Power jumper cord
ZPW-DJ-2FT	2ft. Data jumper cord
ZPW-DJ-10FT	10ft. Data jumper cord
ZPW-DMX-C	DMX Remote controller
ZPW-PWR-CORD	1ft. Cord and plug. 120V 3-Prong plug
ZPW-PJ-15FT	15ft. Power jumper cord
ZPW-DJ-15FT	15ft. Data jumper cord
ZPW-DATA-CORD (Data Starter)	Data Cord



ZPW-DMX-C
DMX Remote Controller
Part #: DMX-Remote



RGB/DMX LINEAR LED WALL WASHERS

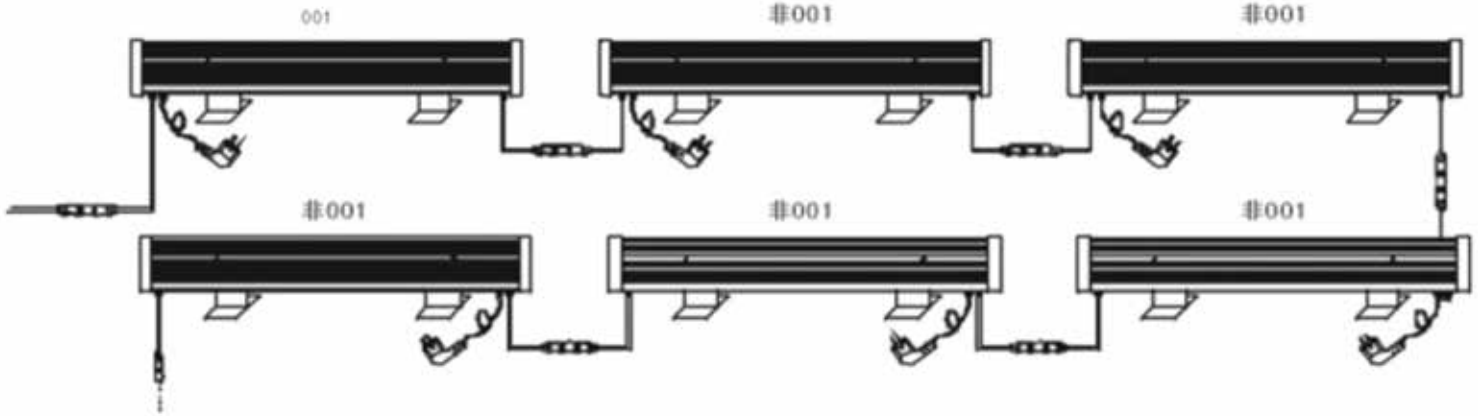

1. When the total length is more than 330 feet or 60 units (product and signal line), a single amplifier should be added.
2. Connect up to 20 wall washers from 1 power source at the beginning of the line.

HOW TO MANUALLY PROGRAM



DMX Address Screen

When you first power the lights they should look like this on the ends:

- This is the DMX address. This is not important for your use since they are being programmed by pushing buttons on the units.
- This is important when you have a separate DMX controller and you would use the address to give commands to specific fixtures.

- Pushing the "A" button selects and makes a number flash.
- Pushing the "B" button makes that selected flashing number change.

X VALUE	Y VALUE
1 - Single Red	1 - 9 Class gray degree
2 - Single Green	1 - 9 Class gray degree
3 - Yellow	1 - 9 Class gray degree
4 - Single Blue	1 - 9 Class gray degree
5 - Purple	1 - 9 Class gray degree
6 - Cyan	1 - 9 Class gray degree
7 - White	1 - 9 Class gray degree
8 - Multi Color Changing	1 - 9 Class speed
9 - Multi Color Fading	1 - 9 Class speed
A - Multi Color Flashing	1 - 9 Class speed

DMX Color Option Screen

- Push the "A" button 3 times to scroll through the DMX address screen and bring you to the DMX color options screen. This is your second of 2 screens.
- In this picture the "8" signifies the color which is "Multi Color Changing".
- The "9" signifies the speed of the transition which should be the slowest speed option.
- When "8" is flashing, you can change it by pressing "B" to scroll through the different colors and transitions.
- Press "A" again to get to the "9". Now press "B" to change the brightness level (for 1-7) or speed (for 8-9).

