

**MADE IN AMERICA**

**BUILD YOUR OWN SEALBRIGHT VAPOR TIGHT - PLS VAPOR TIGHT**

This **fully weatherproof** LED unit is designed for use in wet locations. It can withstand **direct contact with water**, and even be hosed down for easy cleaning, as this unit is **corrosion resistant and waterproof**.



IP65

IP66

IP67



Powered by:



**APPLICATIONS**

- Parking garages
- Industrial Buildings
- Refrigerators / freezers
- Storages
- Car washes
- Shopping centers



See body style for options

**BUILD YOUR OWN SEALBRIGHT VAPOR TIGHT PRODUCT FEATURES - PLS VERSIONS**

<b>WATTAGES</b>	<p><b>Magnilumen Plus:</b> 2ft- 20W, 30W 4ft- 40W, 50W, 60W 8ft- 80W, 100W, 120W</p> <p><b>Magnilumen Plus High Output:</b> 2ft- 30W, 60W 4ft- 60W, 100W, 120W 8ft- 100W, 120W, 240W</p>
<b>COLOR TEMPS</b>	<p><b>Magnilumen Plus:</b> 30K, 35K, 40K, 50K, 65K, Green, Blue, Orange, Yellow, Red, Amber, Black Light</p> <p><b>Magnilumen Plus High Output:</b> 40K, 50K; Special Order: 30K, 35K</p>
<b>LUMENS</b>	See lumens chart
<b>INPUT VOLTAGE</b>	120/277V
<b>CRI</b>	White 83
<b>DIMMING</b>	0-10V
<b>AMBIENT TEMPS</b>	-4°F - 122°F
<b>OPERATING FREQUENCY</b>	50/60Hz
<b>LED LIFESPAN (L70)</b>	<p><b>Magnilumen Plus:</b> 100,000 hours <b>Magnilumen Plus High Output:</b> 50,000 hours</p>
<b>MOUNTING</b>	<p>Available with a stainless steel external hanging bracket. Must be drilled and sealed for each surface mounting or chain hanging application.</p> <p>Latches: Acetal - Plastic Latch included</p>
<b>QUANTITY OF BARS</b>	<p><b>Magnilumen Plus:</b> 2ft + 4ft- 1, 2, or 3 bars 8ft- 2, 4, or 6 bars</p> <p><b>Magnilumen Plus High Output:</b> 2ft- 1 4ft- 1, 2 8ft- 2, 4</p>
<b>MAX WEIGHT</b>	15lbs - 48", 32lbs - 96"
<b>LISTED</b>	UL
<b>LIGHT ENGINE</b>	ETL
<b>OPTIONS</b>	<p>EM + Emergency MS - Motion Sensing</p> <p>Sensors - Optional External PIR Sensor Internal Microwave Sensor Motion Sensor include AO Drivers</p>
<b>RATED</b>	IP65, IP66, IP67, NSF
<b>MAX WASH PRESSURE</b>	PSI PLS - 1500
<b>EMERGENCY BATTERY</b>	Optional 15W or 20W
<b>WARRANTY</b>	<p>Magnilumen Plus 7 year <b>Magnilumen Plus High Output 5 year</b> <b>Magnilumen Plus Color 3 year</b></p>



**BUILD YOUR OWN SEALBRIGHT VAPOR TIGHT – PLS VAPOR TIGHT**

**FIXTURE LENS**  
2ft, 4ft, 8ft:  
Clear Acrylic



**DIMENSIONS – PLS VAPOR TIGHT**

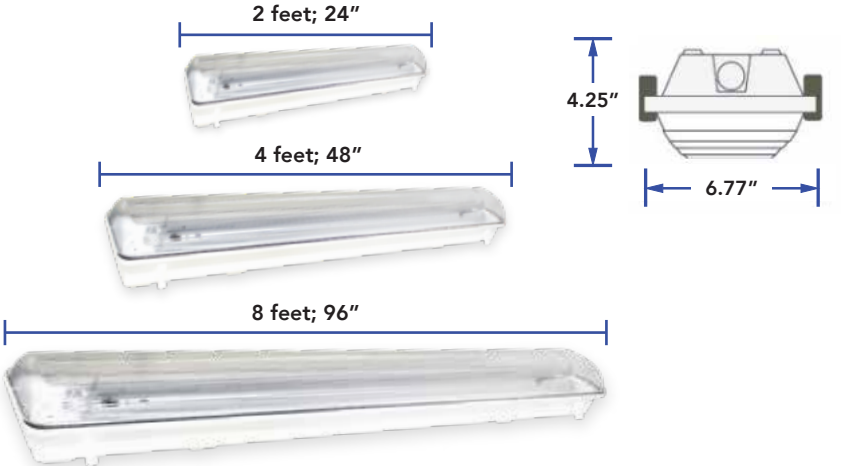

**LUMENS – PLS VAPOR TIGHT**



WATTAGE	LUMENS
20W	3,600L
30W	5,400L
40W	7,200L
50W	9,000L
60W	10,800L



WATTAGE	LUMENS
32W	5,280L
62W	10,230L
100W	16,500L
120W	19,800L

HO Bar per Wattage
30W - 1 - 2 ft bar
62W - 2 - 2 ft bars
62W - 1 - 4 ft bar
120W - 2 - 4 ft bars
240W - 4 - 4 ft bars



**BUILD YOUR OWN SEALBRIGHT VAPOR TIGHT – PLS VAPOR TIGHT**

**MAGNILUMEN PLUS<sup>+</sup>** **PRODUCT BUILDER – PLS VAPOR TIGHT**

PRODUCT #	SIZE	COLOR TEMP	# OF BARS	BAR LENS	FIXTURE LENS	WATTAGE	LATCHES	MOUNTING	OPTIONS
ZL-PLS-LED	2=2FT 4=4FT 8=8FT	30K 35K 40K 50K 65K Amber 585NM Red Green Blue Black Orange Yellow	2ft+4ft 1 2 3 8ft 2 4 6	CL=Clear FR=Frosted Blank=None	CAL=Clear Acrylic Lens	20W 30W 40W 50W 60W 80W 100W 8ft Only 120W	PL=Plastic (included) SSL=Stainless Steel (optional)	SSM=Stainless Steel Mounting (included)	EM15=Emergency Driver 15 Watts EM20=Emergency Driver 20 Watts (w/battery backup) Blank=None  SENSORS (Include Bi-Level) AO Driver Included with Motion Sensor EMS=External Motion Sensing IMS=Internal Motion Sensing

**MAGNILUMEN PLUS<sup>+</sup>** **HIGH OUTPUT**

**HIGH OUTPUT PRODUCT BUILDER – PLS VAPOR TIGHT**

PRODUCT #	SIZE	COLOR TEMP	# OF BARS	BAR LENS	FIXTURE LENS	WATTAGE	LATCHES	MOUNTING	OPTIONS
ZL-PLS-HOLED	2=2FT 4=4FT 8=8FT	40K 50K (Special Order) 30K 35K	2ft 1 4ft 1 2 8ft 2 4	CL=Clear FR=Frosted Blank=None	CAL=Clear Acrylic Lens	2ft 30W 60W 4ft 60W 100W 120W 8ft 100W 120W 240W	SSL=Stainless Steel (included)	SSM=Stainless Steel Mounting (included)	EM20=Emergency Driver 20 Watts (w/battery backup) Blank=None  SENSORS (Include Bi-Level) AO Driver Included with Motion Sensor EMS=External Motion Sensing IMS=Internal Motion Sensing



## ACCESSORIES – PLS VAPOR TIGHT

### SENSORS



**90° Microwave Sensor**  
ZL-SENSOR-HB-HD07R



**90° Remote**  
ZL-HAISEN-REMOTE-HD05R



**Internal Microwave Sensor**  
ZL-MV-SENSOR-ANT-7



**Remote**  
ZL-REMOTE-RC-100

### EMERGENCY DRIVERS

#### FEATURES:

- Local codes can vary
- Standard CSA C22.2 NO. 141, UL924
- External lithium battery
- Battery protections: over charge protection, over discharge protection, short circuit protection
- Indicator shows a variety working modes
- The batteries meet 500 cycles of standard CH and standard DCH
- Emergency 1.5 H

#### PART NUMBERS:

15W: BL-EMRG-LED-15-1H

20W: BL-EMRG-LED-20-1H

WATTAGES	15W, 20W
VOLTAGE INPUT	120/277VAC, 50/60Hz
AC INPUT CURRENT	10mA max
AC INPUT POWER RATING	7.0W max
OUTPUT CURRENT AND VOLTAGE	310-600mA 25-48VDC
BATTERY	Li-ion battery- 14.8V/2000mAH
BATTERY CHARGING CURRENT	250mA
BATTERY CHARGING TIME	24 hours
AMBIENT TEMPERATURE	32 to 104F
EMERGENCY TIME	1.5 hours
TEST SWITCH INDICATOR LIGHT	Illuminated Test Switch, Indicator Light
INSTALLATION	Plug and Play
LISTED	UL
RATED	Title 20
WARRANTY	5 year

#### LUMENS:

	15W	20W
150 lm/W with Frosted Lens	2,250	3,000
170 lm/W with Clear Lens	2,550	3,400
180 lm/W with No Lens	2,700	3,600



Driver Not Included

External Li-ion battery-14.8V/2000mAH

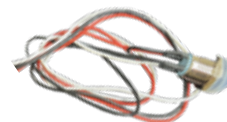

Test Light



15W or 20W  
Emergency Driver



#### DIMENSIONS:

- Driver Dimensions:  
15W: 7.4" x 1.5" x 1.1"  
20W: 7.4" x 1.5" x 1.2"
- Battery Dimensions:  
15W: 6" x 1.5" x .75"  
20W: 6" x 2.25" x .75"

#### OPERATION:

##### AC Operation:

AC power is present, the LED load from the LED driver is normal power supply, AC LED driver output current can not exceed 150W or 4A, the emergency driver is charging in a standby mode, the test switch on to indicate that it is charging.

##### Emergency Operation:

Upon loss of AC input, the emergency driver detects the power interruption and automatically transitions to emergency operating mode. During this state, the green LED indicator is deactivated. When AC power is restored, the driver reverts to normal operation, initiates battery recharge, and reactivates the green LED indicator.

