

LED 180° HORIZONTAL CORN LAMP

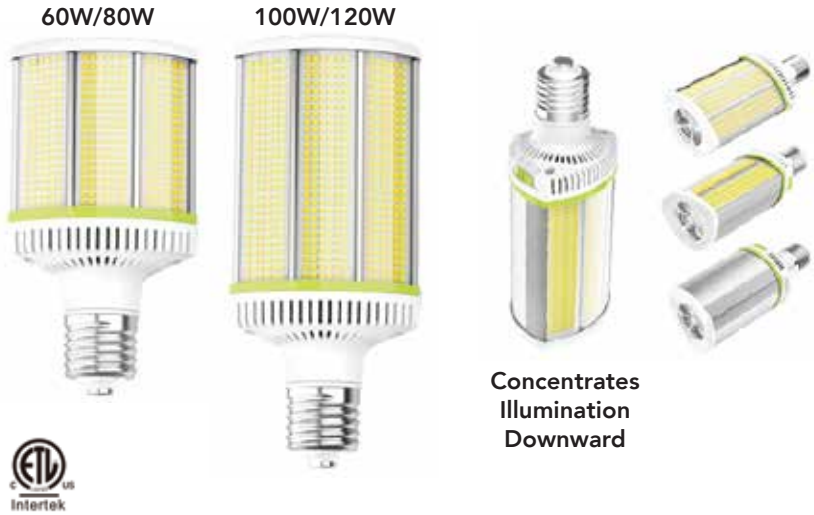

APPLICATIONS

LED 180° Horizontal corn lamps can be widely used in parking lot, street lighting, area light, and canopy fixtures.



PRODUCT SPECIFICATIONS

WATTAGES	60W- 36/48/60W selectable 80W- 48/64/80W selectable 100W- 60/80/100W selectable 120W- 72/96/120W selectable E26 - 60W- 36/48/60W selectable available for special order only. Contact Factory
COLOR TEMPS	45K, 50K, 57K selectable
EFFICACY	150 lm/W
LUMENS	60W- 9,000; 80W- 12,000; 100W- 15,000; 120W- 18,000
INPUT VOLTAGE	120/277V, 480V
CRI	80
BASE TYPE	E39 Mogul
LED LIFESPAN (L70)	50,000 hours
BEAM ANGLE	120°
SUGGESTED HID EQUIV.	100-500W
LISTED	ETL
WARRANTY	5 year
Equipped with fan for active cooling	

PRODUCT BUILDER

ex: ZL-NGT180CL-E39-60W-CCT

TYPE	BASE	WATTAGE	COLOR TEMP	INPUT VOLTAGE
ZL-TGN180CL	E39			
		60W=36/48/60W selectable 80W=48/64/80W selectable 100W=60/80/100W selectable 120W=72/96/120W selectable	CCT=45/50/57K selectable	Blank=120/277V 480V=480V

E26 - 60W- 36/48/60W selectable available for special order only. Contact Factory

LED 180° HORIZONTAL CORN LAMP

DIMENSIONS - 60W/80W

Weight: 1.10 lbs

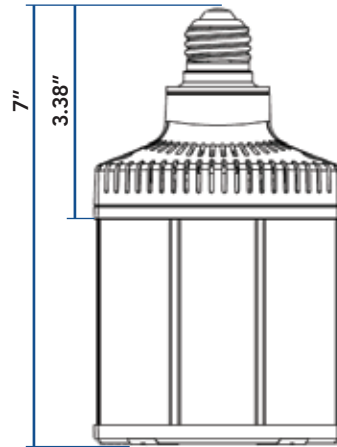
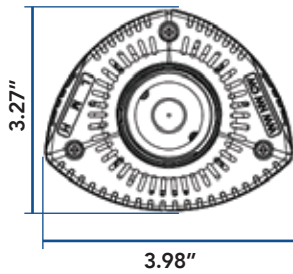

E26 base

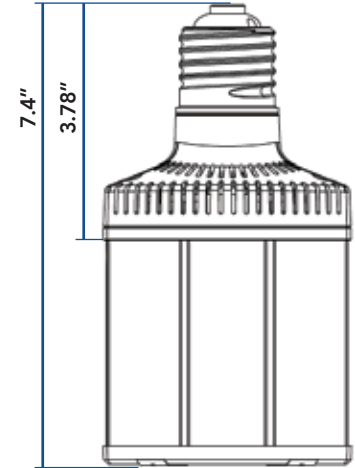

E39 base

E26 - 60W- 36/48/60W selectable
available for special order only.
Contact Factory

STRUCTURE

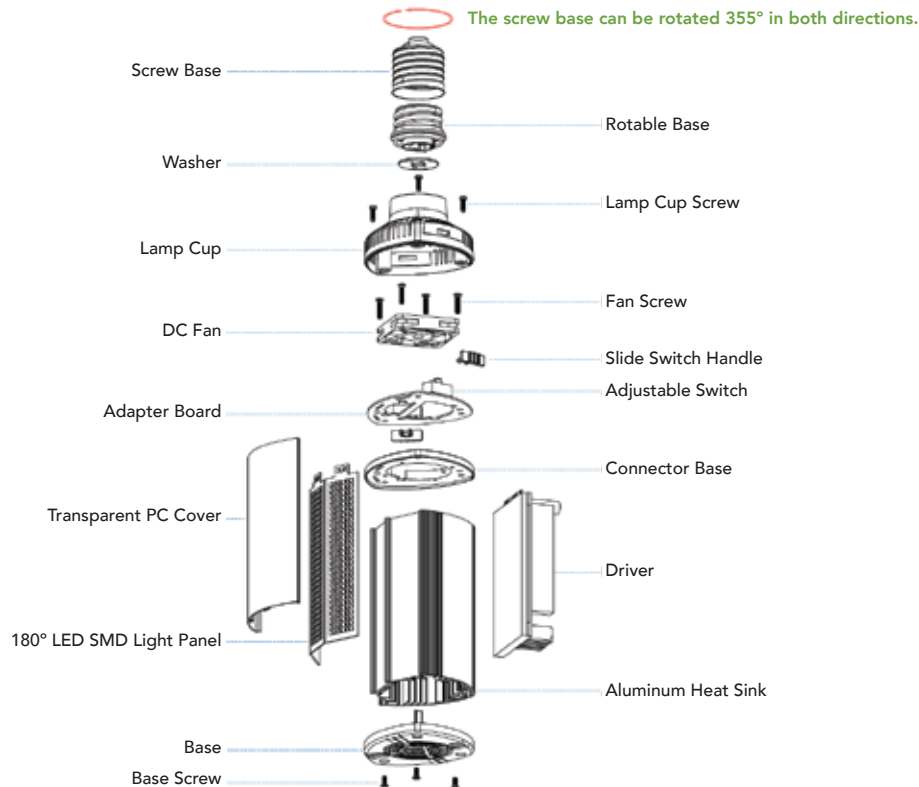

LED 180° HORIZONTAL CORN LAMP

INSTALLATION INSTRUCTIONS

1. Remove old ballast or disconnect from existing lamp holder. Remove and dispose of ballast in correct manner.

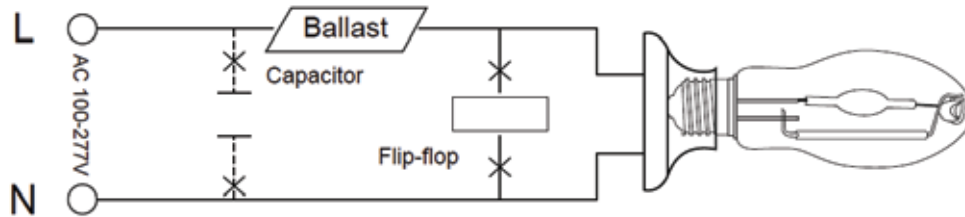

2. Reconnect wire directly to the existing lamp holder.



3. Install new LED Replacement Lamp.

