

LED EMERGENCY DRIVER - UFOs



- **PART NUMBER:** ZL-EM-KIT-100/240W-MK
- **INPUT VOLTAGE:** 100-347VAC
- **OUTPUT VOLTAGE:** 120-200VDC 250V MAX
- **INPUT POWER:** 12W Max
- **EMERGENCY TIME:** 90 minutes
- **CHARGING TIME:** 24 hours
- **BATTERY:** Li-ion battery
- **AMBIENT TEMPERATURE:** 0-50°C; 32-122°F
- **DIMENSIONS:**
- **WARRANTY:** 5 years

UL924 standard and CSA 22.2, No. 141 for USA and Canada.
California Energy Commission (CEC) Title 20 with BC compliant

DIMENSIONS

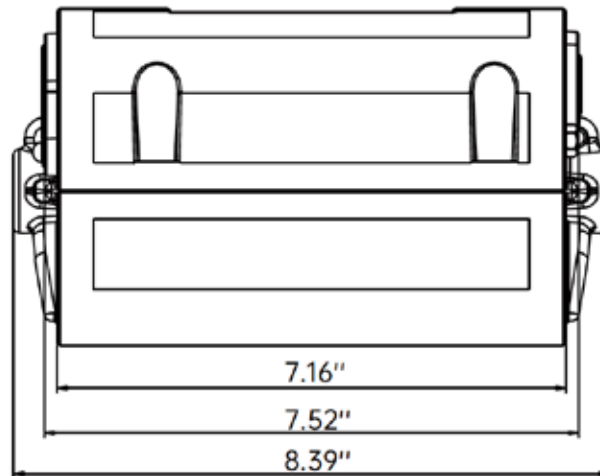

Models	ZL-EM-KIT-100/240W-MK
Emergency Wattage	40W
Battery Capacity	14.8V/6600mAh
Compatible LED Fixture	40-350W LED lamp with 0-10V dimming or LED lamp less than 40W without 0-10V dimming

LED EMERGENCY DRIVER - UFOs

BUILT-IN JUNCTION BOX

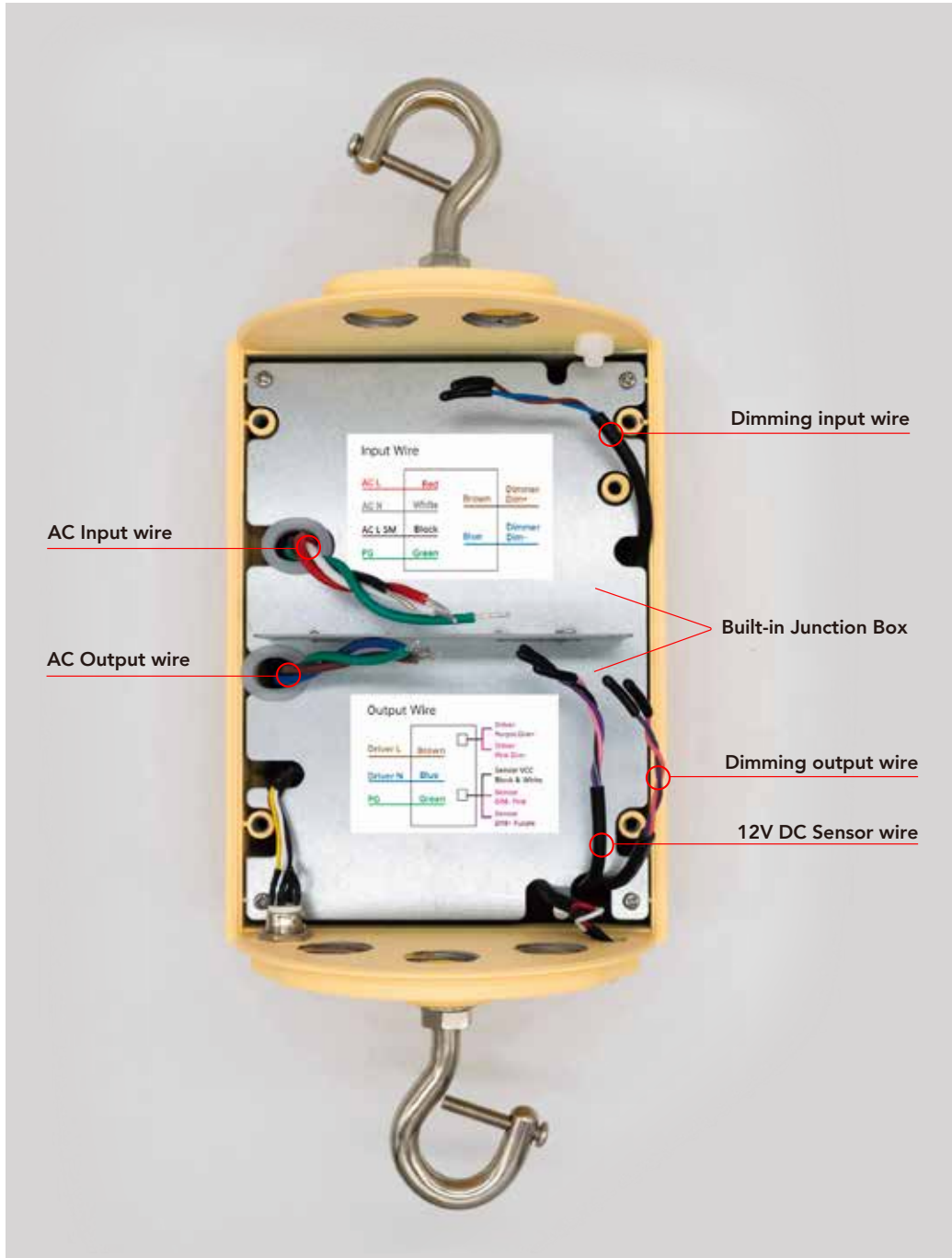

LED EMERGENCY DRIVER - UFOs

MOUNTING

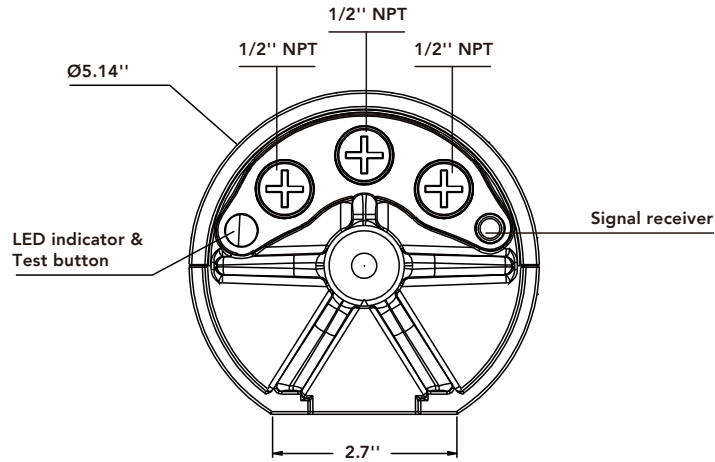

WIRING DIAGRAM

1. With Dimmer ⚠ Driver Power ≥ Emergency Power

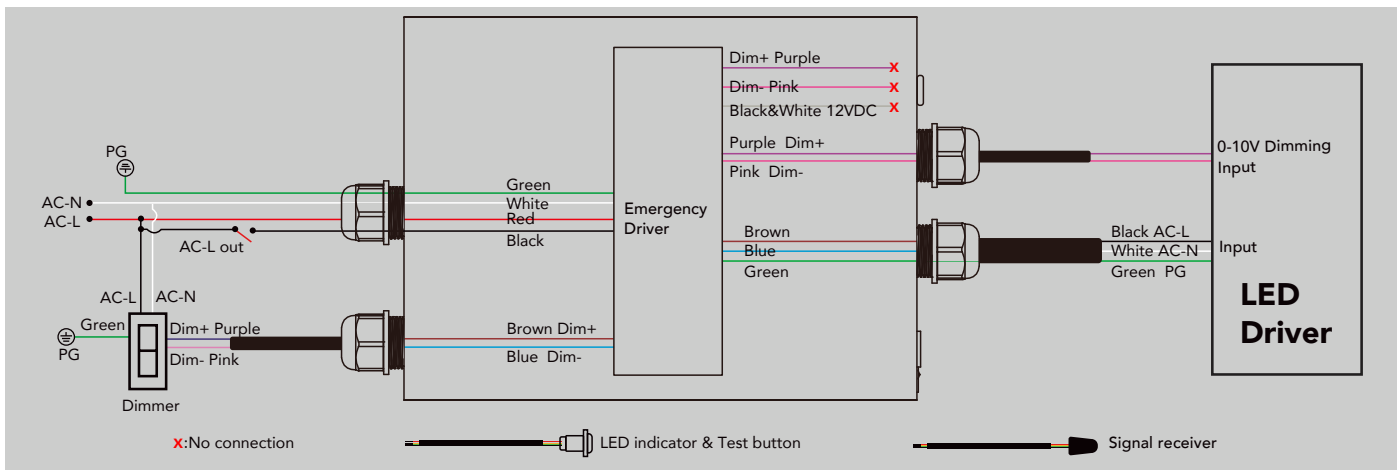

2. With Wall Switch ⚠ Driver Power ≥ Emergency Power

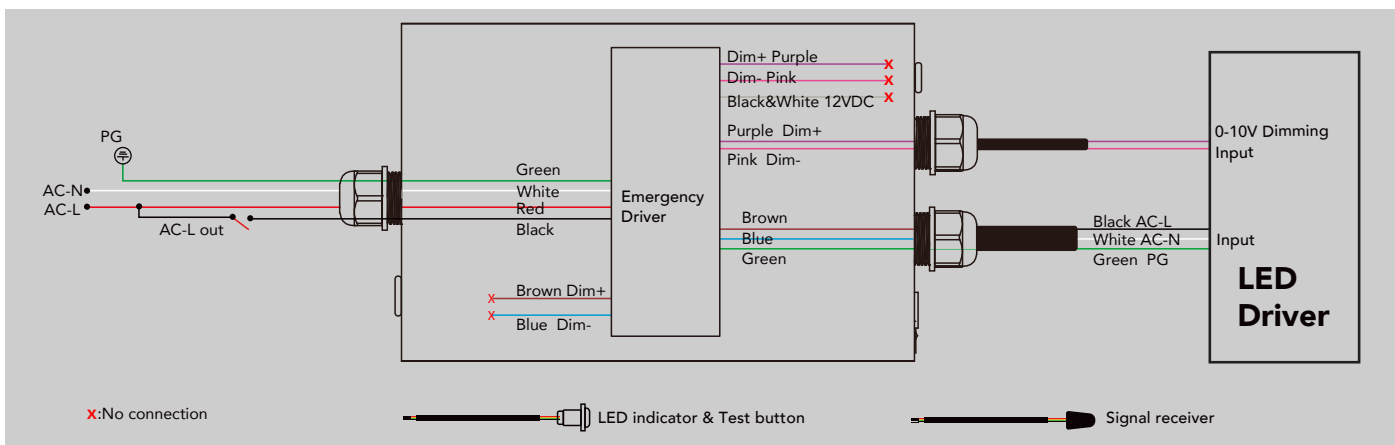

LED EMERGENCY DRIVER - UFOs

WIRING DIAGRAM

3. With 12VDC Sensor ⚠ Driver Power ≥ Emergency Power

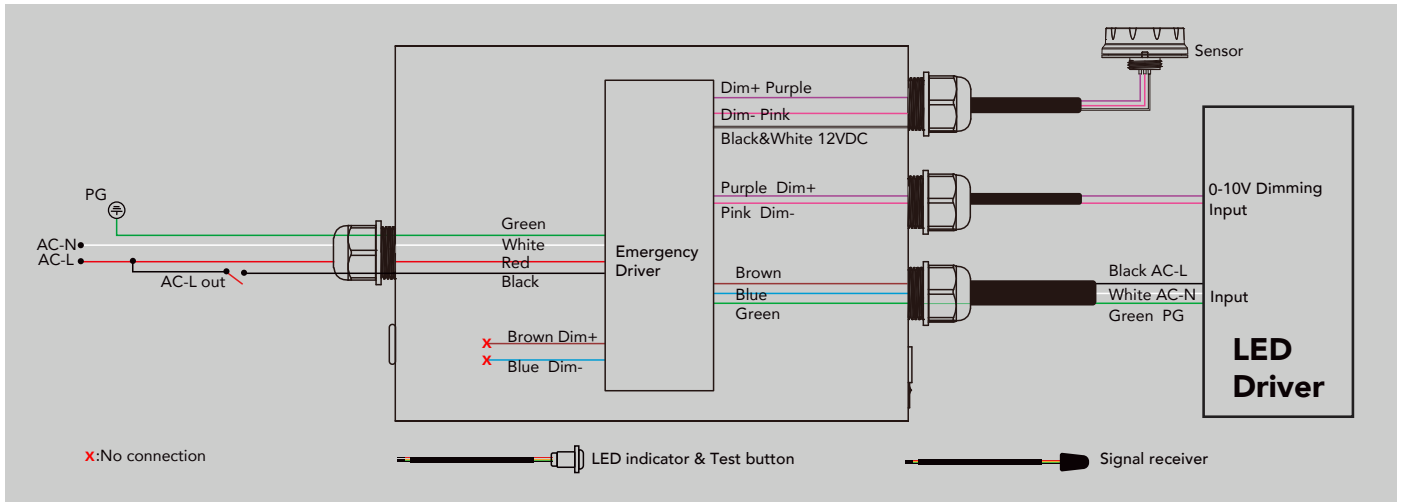

4. With AC Sensor ⚠ Driver Power ≥ Emergency Power

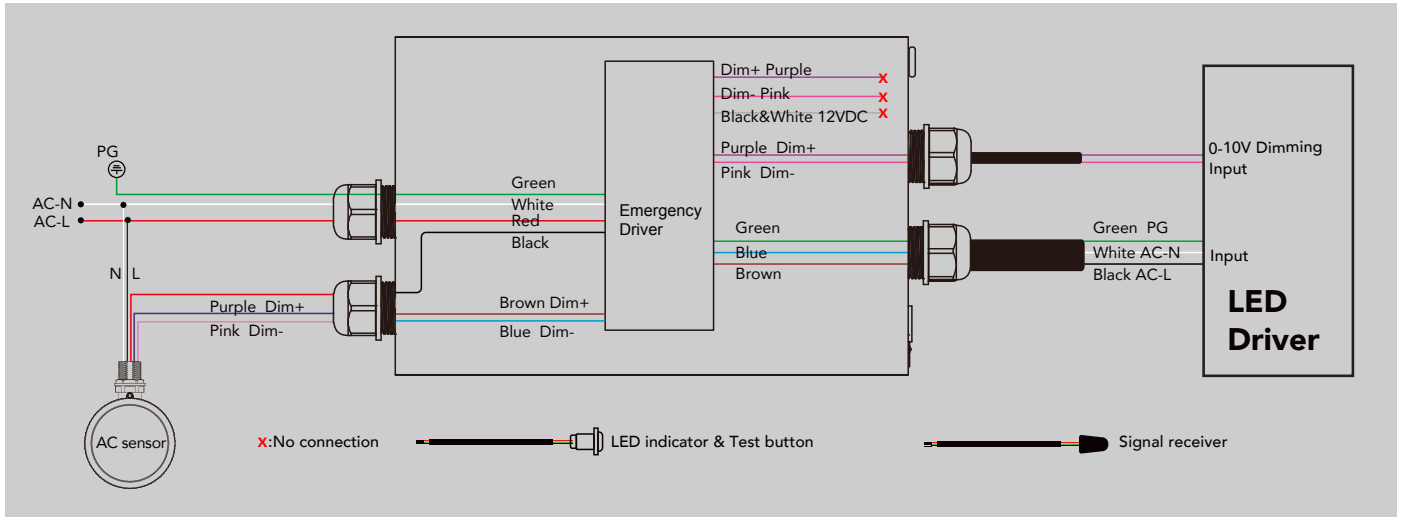

PACKAGING

Part Number	Inner Box Size	Outer Box Size	Pack Quantity	Carton Weight	Net Weight
ZL-EM-KIT-100/240W-MK	13.31" x 6.46" x 5.24"	13.59" x 14.06" x 16.74"	6 pcs	31.29 lbs	25.8 lbs