

## LED EMERGENCY DRIVERS

We offer a series of Emergency Driver to be used with **Magnilumen Plus, Downlights, Flat Panels, Troffers and High Bays.**



### FEATURES

- This EM drivers allows the same LED fixture to be used for both normal and emergency operation in the event of a power failure.
- Meets safety standards for lighting.
- Internal Lithium battery.
- Battery protections: over charge protection, over discharge protection, short circuit protection.
- Indicator shows a variety working modes.
- Intelligent emergency automatic detection function.
- The batteries meet 500 cycles of standard charge and discharge constant output power (Auto-sensing output within each range).

## MAGNILUMEN PLUS KITS

- **MODEL:** 15W
- **PART NUMBER:** BL-EMRG-LED-15-1H
- **INPUT VOLTAGE:** 100-277VAC
- **OUTPUT VOLTAGE:** 25-48VDC
- **EMERGENCY POWER:** 15W
- **EMERGENCY TIME:** 90 mins
- **DIMENSIONS:** 7.41" x 1.5" x 1.14"
- **AMBIENT TEMPERATURE:** 32-122F
- **BATTERY:** Lithium
- **WARRANTY:** 5 years



### DIMENSIONS

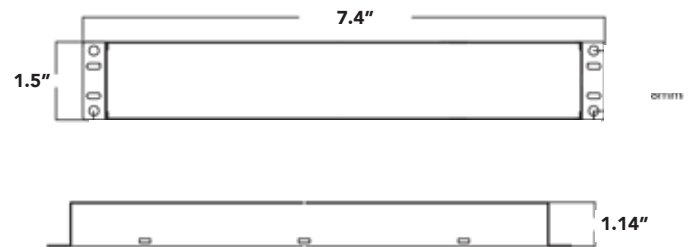

### WIRING DIAGRAM

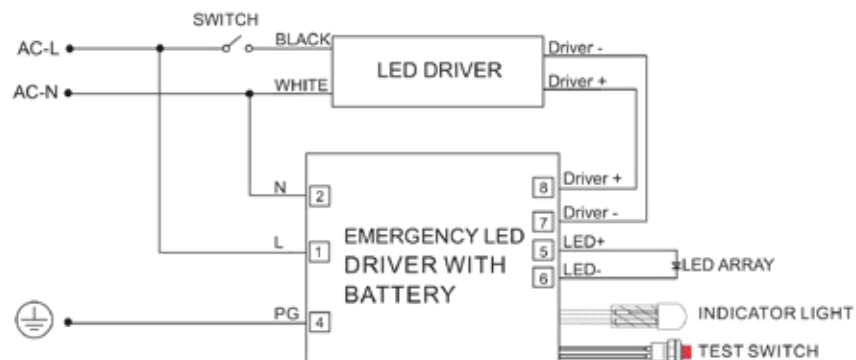

## DOWNLIGHTS

- **MODEL:** 8W
- **PART NUMBER:** BL-EMRGFXT-8D-A
- **INPUT VOLTAGE:** 100-347VAC
- **OUTPUT VOLTAGE:** 170VDC
- **EMERGENCY POWER:** 8W
- **EMERGENCY TIME:** 90 mins
- **DIMENSIONS:** 10.3" x 1.85" x 0.94"
- **AMBIENT TEMPERATURE:** 32-122F
- **BATTERY:** Lithium
- **WARRANTY:** 5 years



Specifications and actual product may vary.

Office (800) 679-9243 • sales@zledlighting.com • www.zledlighting.com

### DIMENSIONS

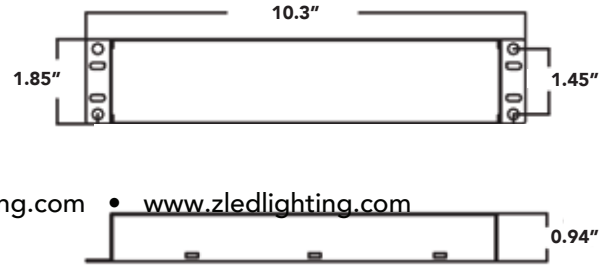

## FLAT PANELS AND TROFFERS

- **MODEL:** 15W
- **PART NUMBER:** BL-EMRG-FXT-15D-A
- **INPUT VOLTAGE:** 100-347VAC
- **OUTPUT VOLTAGE:** 170VDC
- **EMERGENCY POWER:** 15W
- **EMERGENCY TIME:** 90 mins
- **DIMENSIONS:** 13.77" x 1.97" x 0.94"
- **AMBIENT TEMPERATURE:** 32-122F
- **BATTERY:** Lithium
- **WARRANTY:** 5 years



### DIMENSIONS

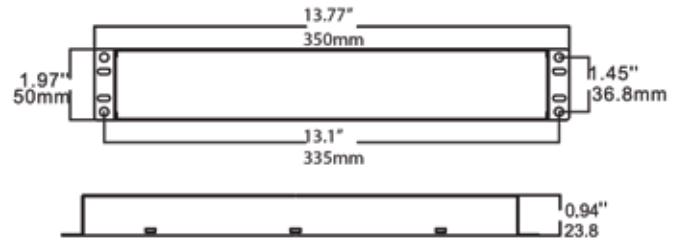

## HIGH BAYS

- **MODEL:** 25W
- **PART NUMBER:** BL-EMRG-FXT-25D-A
- **INPUT VOLTAGE:** 100-347VAC
- **OUTPUT VOLTAGE:** 170VDC
- **EMERGENCY POWER:** 25W
- **EMERGENCY TIME:** 90 mins
- **DIMENSIONS:** 13.1" x 1.97" x 0.94"
- **AMBIENT TEMPERATURE:** 32-122F
- **BATTERY:** Lithium
- **WARRANTY:** 5 years



### DIMENSIONS

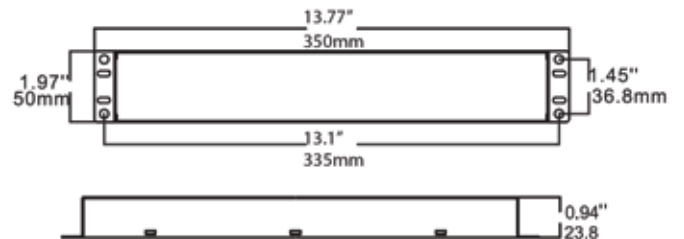

### WIRING DIAGRAM

- For Downlights, Flat Panels, Troffers and High Bays
- 8W, 15W, 25W

